

Please check the examination details below before entering your candidate information

Candidate surname

Other names

Centre Number

Candidate Number

--	--	--	--	--

--	--	--	--

## Pearson Edexcel Level 3 GCE

Time 2 hours 30 minutes

Paper  
reference

**9PH0/03**

### Physics

Advanced

**PAPER 3: General and Practical Principles in Physics**

**You must have:**

Scientific calculator, ruler

Total Marks

### Instructions

- Use **black** ink or ball-point pen.
- **Fill in the boxes** at the top of this page with your name, centre number and candidate number.
- Answer **all** questions.
- Answer the questions in the spaces provided  
– *there may be more space than you need.*

### Information

- The total mark for this paper is 120.
- The marks for **each** question are shown in brackets  
– *use this as a guide as to how much time to spend on each question.*
- In questions marked with an **asterisk** (\*), marks will be awarded for your ability to structure your answer logically, showing how the points that you make are related or follow on from each other where appropriate.
- The list of data, formulae and relationships is printed at the end of this booklet.

### Advice

- Read each question carefully before you start to answer it.
- Try to answer every question.
- Check your answers if you have time at the end.
- You are advised to show your working in calculations including units where appropriate.

Turn over ►

P69444A

©2022 Pearson Education Ltd.

Q:1/1/1/1/



  
Pearson

**Answer ALL questions in the spaces provided.**

- 1 A student investigated the behaviour of a spring under tension. The spring was hung vertically with a mass holder attached, as shown. The position of the bottom of the mass holder was determined using a metre rule.

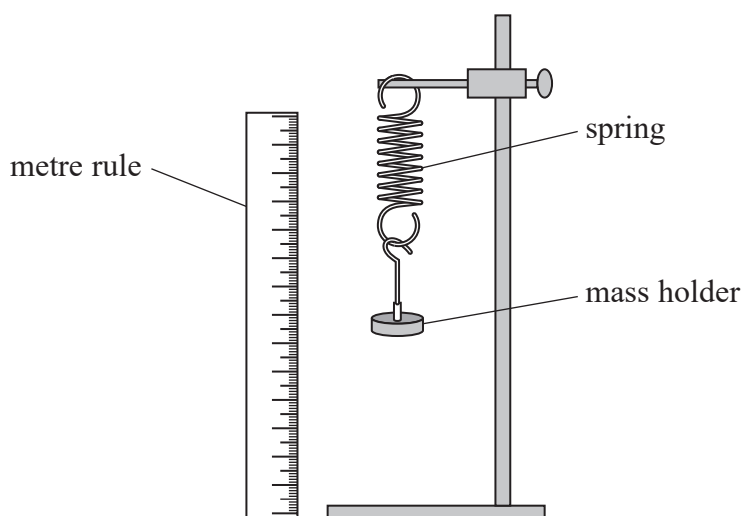

- (a) The position of the bottom of the mass holder was recorded. The spring was stretched by adding masses to the mass holder and the new positions were determined. The extension of the spring for each mass was calculated.

The results are shown in the table.

Mass / kg	Extension / m
0.05	0.019
0.10	0.042
0.15	0.058
0.20	0.085
0.25	0.1
0.35	0.14

Criticise the recording of these results.

(2)

.....

.....

.....

.....

DO NOT WRITE IN THIS AREA

DO NOT WRITE IN THIS AREA

DO NOT WRITE IN THIS AREA



(b) Describe how the student should determine the extension of the spring as accurately as possible.

(3)

.....

.....

.....

.....

.....

.....

.....

**(Total for Question 1 = 5 marks)**

DO NOT WRITE IN THIS AREA

DO NOT WRITE IN THIS AREA

DO NOT WRITE IN THIS AREA



P 6 9 4 4 4 A 0 3 3 6

2 A student was given a box of identical glass microscope slides and asked to determine the density of the glass. She used a micrometer to measure the thickness of one of the slides. She repeated this measurement twice in different places and calculated a mean value for the thickness. The thickness of each slide was approximately 1 mm.

(a) Explain how she should have measured the thickness of the slides in order to minimise the percentage uncertainty.

(2)

.....

.....

.....

(b) In her report she wrote

*"My value for the mass of the glass slides was precise, because I measured the mass using an electronic balance which was accurate to the nearest 0.01g. I reduced the effect of random error by repeating the measurement several times."*

Comment on this statement.

(4)

.....

.....

.....

.....

.....

.....

.....

.....

.....

**(Total for Question 2 = 6 marks)**



- 3 It was suggested on an online forum that it would be possible to cook a chicken by repeatedly slapping the chicken with one hand.

It was claimed that the energy transferred to a chicken in 8000 slaps would be sufficient to raise the temperature of the chicken from  $23\text{ }^{\circ}\text{C}$  to  $165\text{ }^{\circ}\text{C}$ .

In an investigation to test the claim, the effective mass of the hand was taken as  $1.75\text{ kg}$  and the speed of the hand just before impact with the chicken as  $6.25\text{ m s}^{-1}$ .

- (a) Deduce whether the data confirms that 8000 slaps would be sufficient.  
Assume that no energy is transferred from the chicken to the surroundings.

mass of chicken =  $0.875\text{ kg}$

specific heat capacity of chicken =  $1770\text{ J kg}^{-1}\text{ K}^{-1}$

efficiency of energy transfer from the hand =  $65\%$

(5)

- (b) Explain whether the assumption made in (a) is realistic.

(2)

(Total for Question 3 = 7 marks)



- 4 The diagram shows a metronome, which includes an inverted pendulum, used by musicians to set a tempo. The pendulum oscillates with simple harmonic motion and makes a loud click at regular intervals.

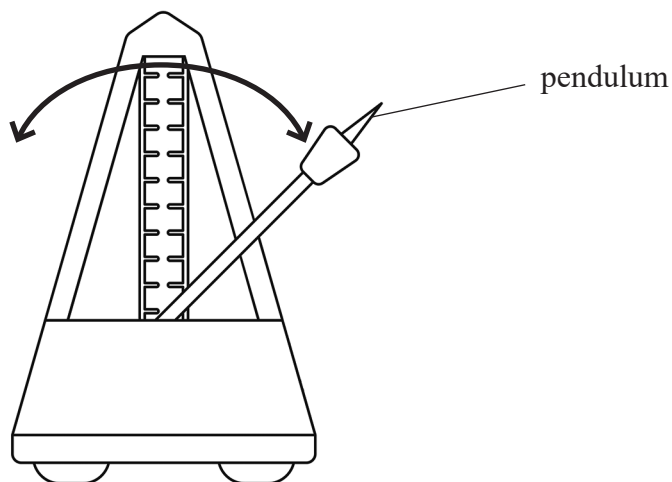

(Source: Getty Images)

A faulty metronome stopped making a clicking noise. A student tried to check the accuracy of the period  $T$  of the metronome, using a stopwatch. The student timed the pendulum as it moved from one extreme of the oscillation to the other.

Explain how the procedure used by the student to determine  $T$  could have been improved.

.....

.....

.....

.....

.....

.....

.....

.....

.....

.....

(Total for Question 4 = 5 marks)



DO NOT WRITE IN THIS AREA

DO NOT WRITE IN THIS AREA

DO NOT WRITE IN THIS AREA

**BLANK PAGE**



\*5 The diagram shows a 'shaker torch'. When the torch is shaken, a strong magnet moves forwards and backwards through a copper coil, powering a light-emitting diode (LED).

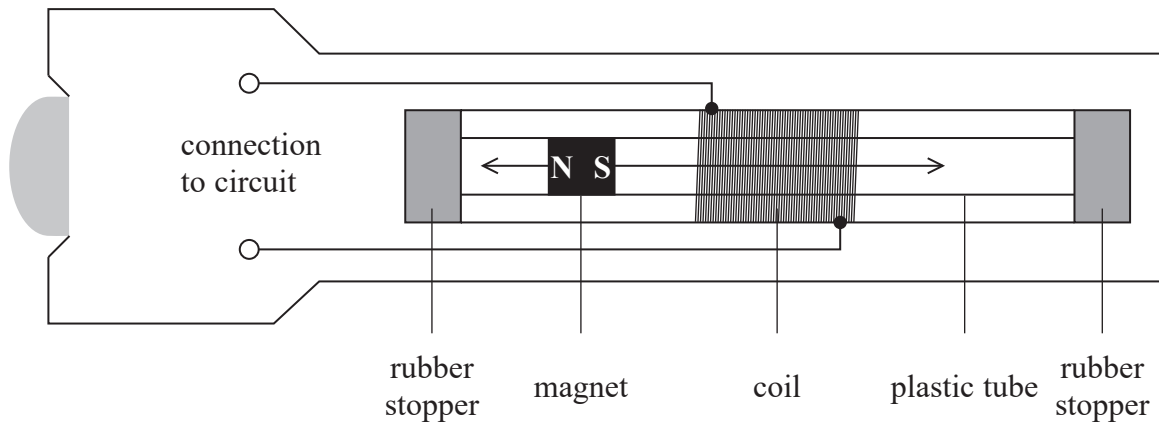

Each time the magnet moves through the coil a current pulse is generated. The coil is connected to a capacitor via a diode, as shown.

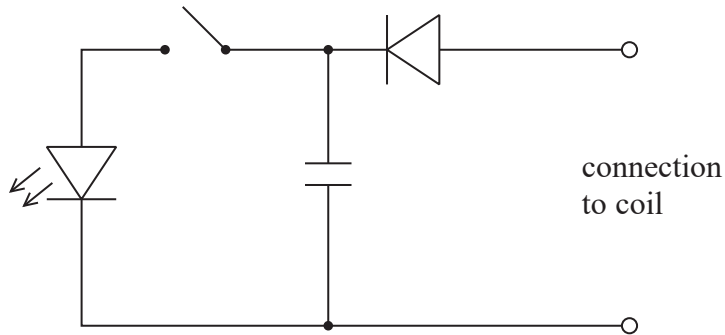

Once the torch has been shaken for a few minutes the switch is closed and the LED lights for a short while.

DO NOT WRITE IN THIS AREA

DO NOT WRITE IN THIS AREA

DO NOT WRITE IN THIS AREA





Explain how the shaker torch is able to light the LED.

DO NOT WRITE IN THIS AREA

DO NOT WRITE IN THIS AREA

DO NOT WRITE IN THIS AREA

Area with horizontal dotted lines for writing the answer.

**(Total for Question 5 = 6 marks)**

Large empty rectangular area for additional notes or calculations.



- 6 In an experiment to determine the speed of sound in air a student connected two microphones to an oscilloscope, as shown.

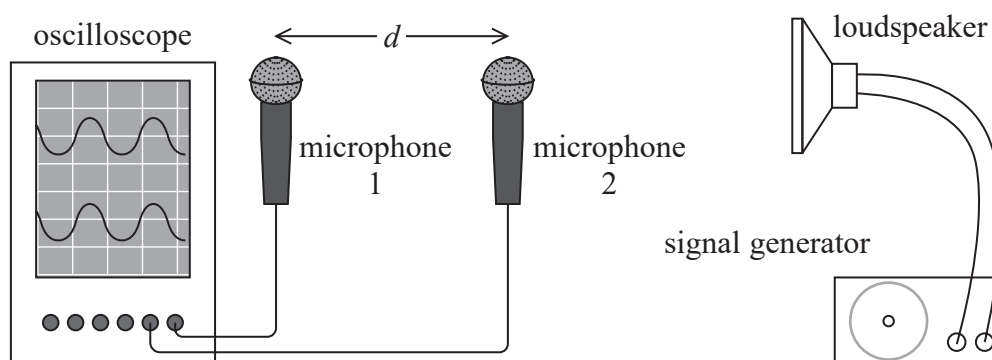

The microphones detect sound from the loudspeaker, converting it to an electrical signal. The signal is displayed on the oscilloscope screen.

Both microphones were initially positioned the same distance from the loudspeaker. The two signals were in phase on the oscilloscope screen. The student slowly moved microphone 2 towards the loudspeaker, until the two signals on the oscilloscope were in phase again. He then measured the distance  $d$  between the microphones to determine the wavelength  $\lambda$  of the sound waves.

$$d = 20.5 \text{ cm}$$

- (a) Comment on the student's experimental technique to determine  $\lambda$ .

(2)

.....

.....

.....

.....

.....

DO NOT WRITE IN THIS AREA

DO NOT WRITE IN THIS AREA

DO NOT WRITE IN THIS AREA



(b) The oscilloscope trace for the signal from microphone 1 is shown below.

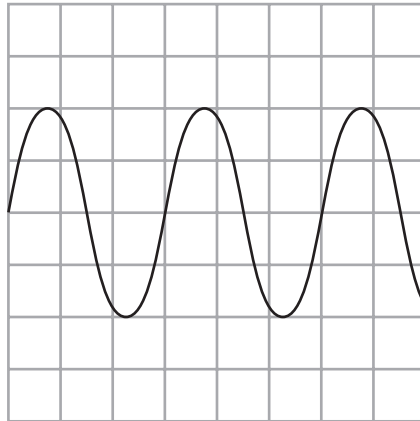

The time base of the oscilloscope was set to  $0.20 \text{ ms div}^{-1}$ .

Determine a value for the speed of sound in air.

(5)

Speed of sound = .....

(Total for Question 6 = 7 marks)



- 7 A projectile of mass 65 g is fired vertically upwards into a stationary wooden block of mass 2.400 kg, as shown.

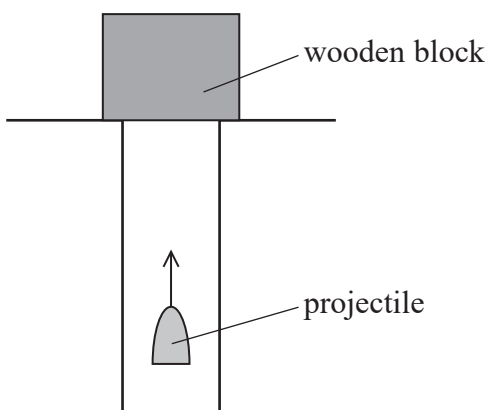

- (a) The projectile becomes embedded in the block. They both move vertically upwards through a vertical displacement of 55 cm before momentarily coming to rest.

Calculate the energy dissipated as the projectile hits the block.

(6)

.....

.....

.....

.....

.....

.....

.....

.....

.....

.....

.....

.....

.....

.....

.....

Energy dissipated = .....

DO NOT WRITE IN THIS AREA

DO NOT WRITE IN THIS AREA

DO NOT WRITE IN THIS AREA



(b) Explain how the principle of conservation of energy applies to this collision.

(2)

.....

.....

.....

.....

.....

**(Total for Question 7 = 8 marks)**

DO NOT WRITE IN THIS AREA

DO NOT WRITE IN THIS AREA

DO NOT WRITE IN THIS AREA



P 6 9 4 4 4 A 0 1 3 3 6

- 8 A teacher demonstrated the decay of protactinium using a Geiger-Müller (GM) tube connected to a data logger.

A sealed plastic bottle contains a solvent floating above a liquid containing a uranium salt. Protactinium is produced from the decay of uranium and is present in the solvent as shown.

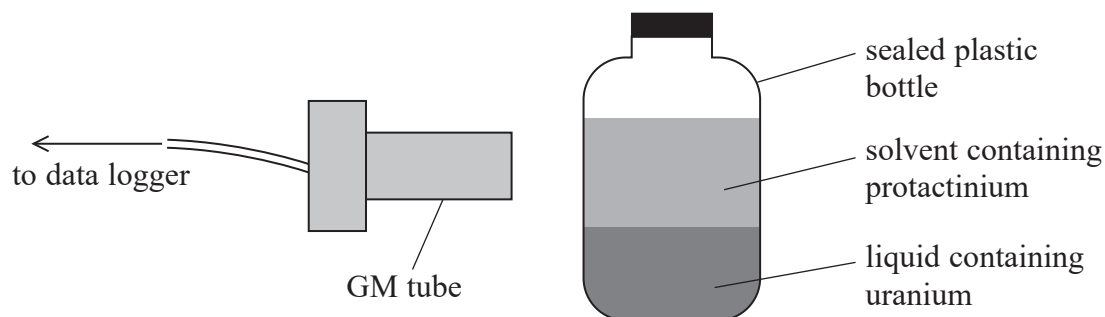

- (a) Deduce whether alpha radiation or beta radiation from the inside of the bottle is detected by the GM tube.

(2)

- (b) The data logger output is shown below.

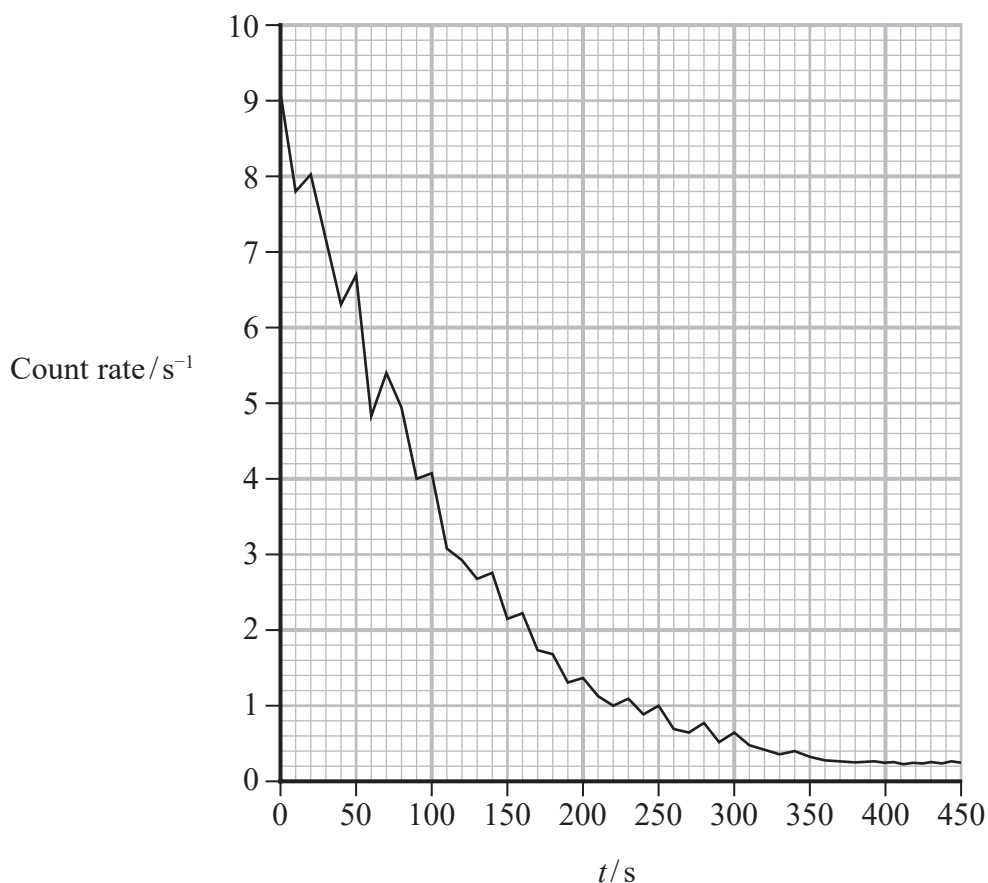

(i) Determine the half-life of the protactinium.

(4)

.....

.....

.....

.....

.....

.....

.....

.....

.....

.....

Half-life of protactinium = .....

(ii) Explain why the count rate doesn't reach zero.

(2)

.....

.....

.....

.....

**(Total for Question 8 = 8 marks)**

DO NOT WRITE IN THIS AREA

DO NOT WRITE IN THIS AREA

DO NOT WRITE IN THIS AREA



- 9 A student is planning to collect data to produce a current-potential difference graph for a filament lamp. Her teacher suggests two circuits that she could use.

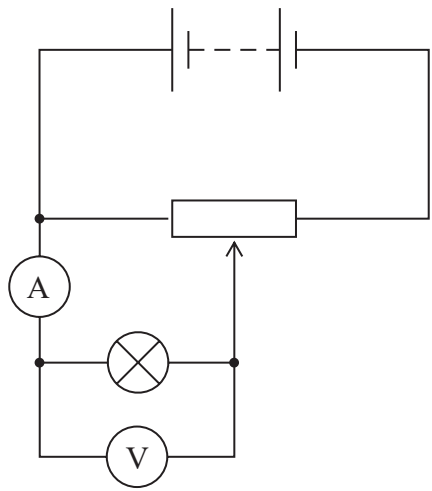

Circuit 1

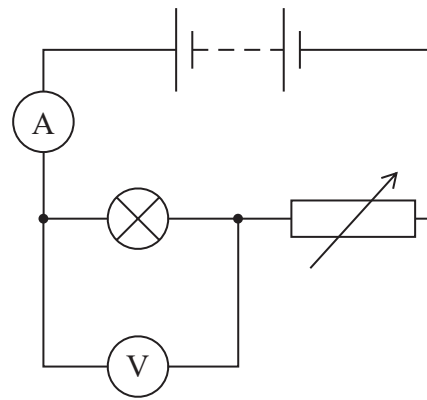

Circuit 2

Circuit 1 uses a potential divider and circuit 2 uses a variable resistor to vary the potential difference across the filament lamp.

- \*(a) Discuss the suitability of each circuit to collect the data.

(6)

.....

.....

.....

.....

.....

.....

.....

.....

.....

.....

.....

.....

.....

.....

.....

.....





- (b) The student sets up the following circuit with the filament lamp. The battery has negligible internal resistance.

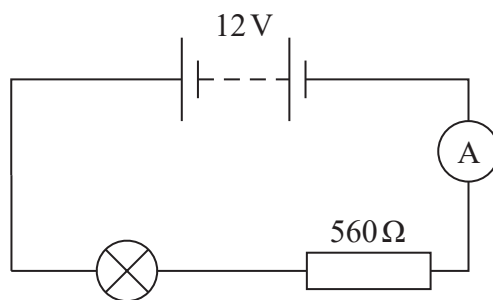

- (i) The reading on the ammeter is 17.5 mA.

Calculate the value of the potential difference (p.d.) across the filament lamp.

(2)

p.d. across filament lamp = .....

- (ii) When a voltmeter with a resistance of 1.5 k $\Omega$  is connected as shown, the p.d. across the filament lamp decreases.

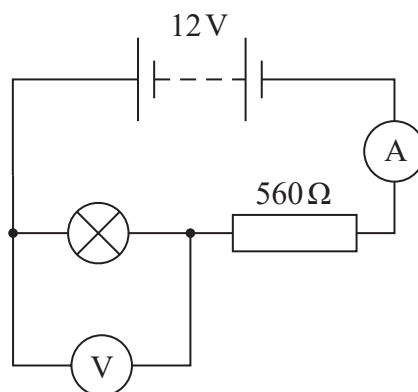

Explain why the p.d. across the filament lamp decreases.

(3)

(Total for Question 9 = 11 marks)

- 10 A student carried out an experiment to determine the viscosity of some honey. He filled a tall glass cylinder with honey as shown, and timed a ball bearing as it fell through the honey.

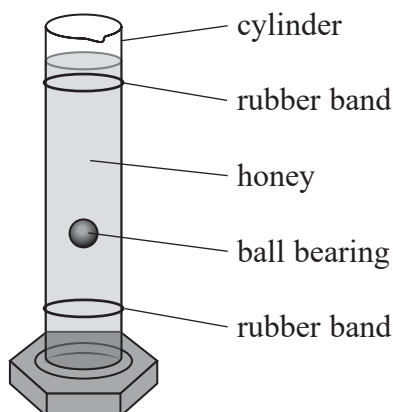

- (a) The student placed rubber bands near the top and bottom of the cylinder. He started a stopwatch when the ball bearing passed the first band and stopped the stopwatch when the ball bearing passed the second band. He repeated this several times to determine a mean time.

Criticise the student's method.

(2)

- (b) The time  $t$  for the sphere to fall through a distance of 25.0 cm is shown in the table.

$t/s$			
6.40	6.35	6.36	6.38

- (i) Show that the mean velocity  $v$  of the ball bearing is about  $0.04 \text{ m s}^{-1}$ .

(3)



(ii) The student had three different types of honey available.

Viscosity  $\eta$  is given by the following expression

$$\eta = \frac{2r^2g(\rho_B - \rho_H)}{9v}$$

radius  $r$  of ball bearing =  $5.50 \times 10^{-3}$  m

density of ball bearing  $\rho_B = 7750 \text{ kg m}^{-3}$

density of honey  $\rho_H = 1360 \text{ kg m}^{-3}$

Viscosity (at 20°C)/Pa s		
Honey A	Honey B	Honey C
10.6	12.5	13.6

Deduce which honey the student used.

(2)

.....

.....

.....

.....

.....

(Total for Question 10 = 7 marks)

DO NOT WRITE IN THIS AREA

DO NOT WRITE IN THIS AREA

DO NOT WRITE IN THIS AREA



P 6 9 4 4 4 A 0 1 9 3 6

- 11 A student carried out an experiment to calibrate a thermistor. She connected the thermistor in series with a resistor and a power supply as shown. Then she placed the thermistor in a beaker of hot water and used a thermometer to record the temperature  $\theta$  of the water.

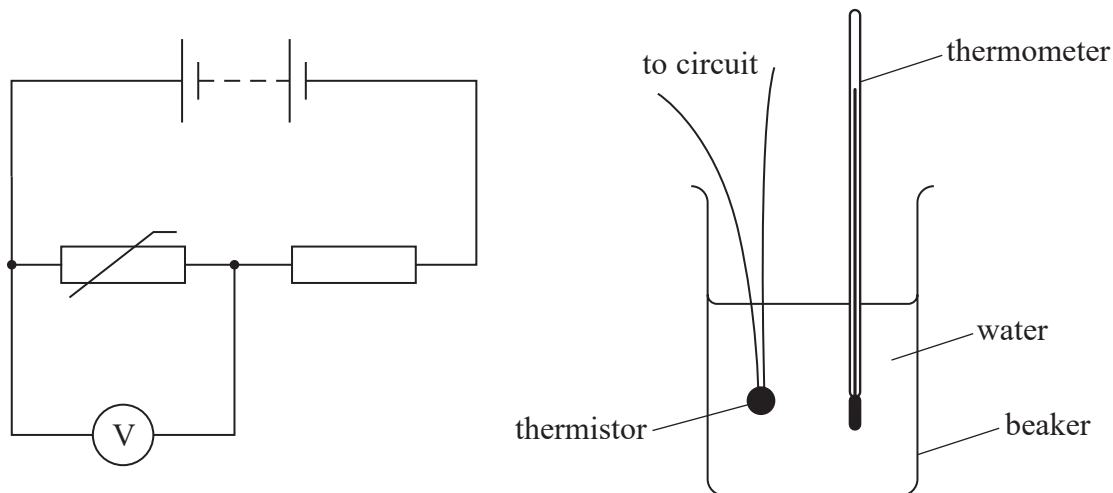

The student recorded  $\theta$  and corresponding values of the reading  $V$  on the voltmeter as the water cooled.

- (a) Explain, making reference to charge carriers, why  $V$  increased as the water cooled.

(3)



(b) Over a limited temperature range  $V$  varies with  $\theta$  according to the expression

$$V = V_0 e^{-b\theta}$$

where  $b$  and  $V_0$  are constants.

(i) Explain why a graph of  $\ln V$  against  $\theta$  would give a straight line.

(2)

.....

.....

.....

.....

DO NOT WRITE IN THIS AREA

DO NOT WRITE IN THIS AREA

DO NOT WRITE IN THIS AREA



P 6 9 4 4 4 A 0 2 1 3 6

(ii) The student's data is shown in the table below.

$\theta/^\circ\text{C}$	$V/V$	
89.0	1.9	
74.0	2.9	
53.5	4.9	
32.5	9.1	
18.5	12.6	
3.5	18.7	

Plot a graph of  $\ln V$  against  $\theta$  on the grid opposite. Use the column provided to show any processed data.

(5)

(iii) Determine values for  $b$  and  $V_0$ .

(4)

.....

.....

.....

.....

.....

.....

.....

.....

$$b = \text{.....}$$

$$V_0 = \text{.....}$$



DO NOT WRITE IN THIS AREA

DO NOT WRITE IN THIS AREA

DO NOT WRITE IN THIS AREA

(Total for Question 11 = 14 marks)



P 6 9 4 4 4 A 0 2 3 3 6

12 In 2011, a tsunami was caused by a massive earthquake centred some distance off the coast of Japan. The tsunami caused a cooling system failure at the Fukushima Nuclear Power Plant. This resulted in a nuclear meltdown and radioactive materials were released into the surroundings.

(a) A reservoir beside one of the reactor buildings contained a large volume of water. In 2013, this water was found to have an extremely high concentration of caesium-137.

Caesium-137 is a radioactive isotope of caesium.

(i) Complete the nuclear equation for the decay of caesium-137.

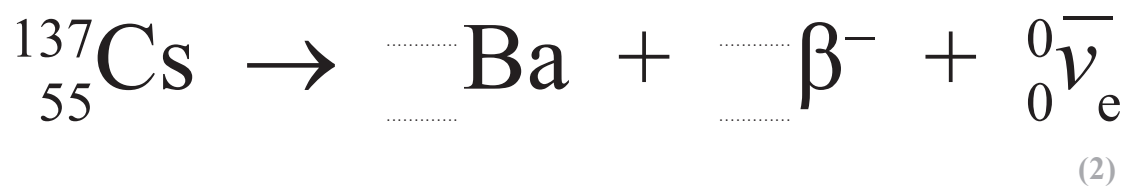

(ii) An activity of  $2.35 \times 10^{12}$  Bq per  $\text{m}^3$  of water in the reservoir was measured. It is suggested that a safe level for the activity of all water in the reservoir would be 100 Bq.

Calculate the time in years for the caesium-137 to decay to a safe level.

volume of water in reservoir =  $5000 \text{ m}^3$

half-life of caesium-137 = 30 years

(4)

Time = ..... years





DO NOT WRITE IN THIS AREA

DO NOT WRITE IN THIS AREA

DO NOT WRITE IN THIS AREA

(b) The most common radionuclide amongst the fission products in the fuel was iodine-131, which decays with a half-life of 8.0 days to form a stable isotope of the gas xenon.

Deduce whether enough xenon would have collected in 32 days to exert a pressure of  $1.0 \times 10^5$  Pa in a volume of  $450 \text{ m}^3$ . Assume that no gas escapes.

temperature =  $20^\circ\text{C}$

initial number of iodine nuclei =  $1.25 \times 10^{28}$

(6)

.....

.....

.....

.....

.....

.....

.....

.....

.....

.....

.....

.....

.....

.....

.....

.....

.....

.....

.....

.....



- (c) Buildings in nearby Tohoku University suffered structural damage during the 2011 earthquake.

The graph shows how the acceleration of one of the buildings, measured on the 9th floor, varied with time during the earthquake.

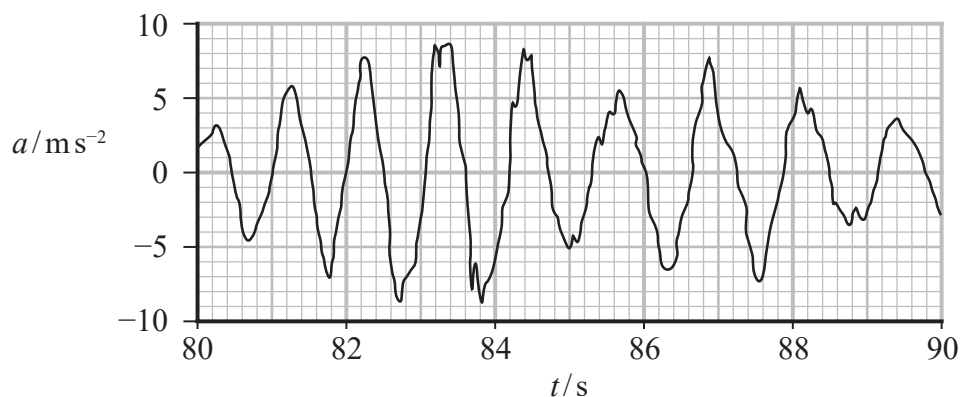

(Source: <https://www.sciencedirect.com/science/article/pii/S0038080612001035>)

At the time it was reported that during the earthquake the 9th floor of the building displaced by more than 30 cm from its normal position.

Assess the accuracy of this report.

(5)

(Total for Question 12 = 17 marks)



DO NOT WRITE IN THIS AREA

DO NOT WRITE IN THIS AREA

DO NOT WRITE IN THIS AREA

13 A student used a sonometer to investigate the properties of a stretched wire. The sonometer is a long hollow wooden box.

A steel wire is attached to one end of the box and rests on two wooden bridges. The wire is placed under tension  $T$  by hanging a mass from the end of the wire, as shown.

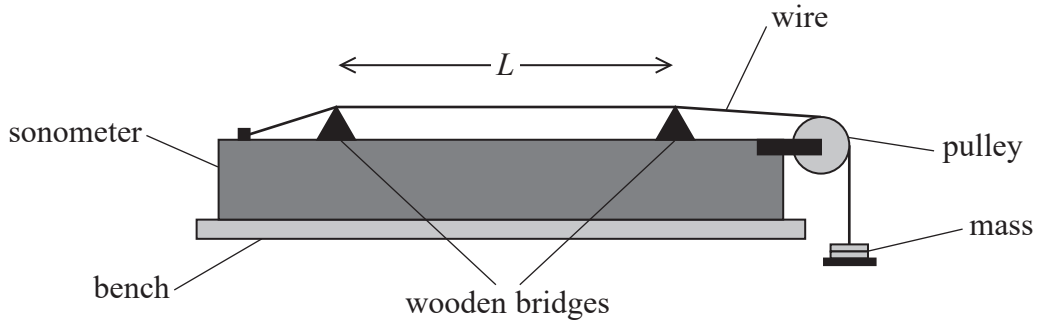

The student placed the base of a vibrating tuning fork in contact with the wire, at one of the bridges. This set the wire into oscillation. He adjusted the position of the other bridge until a single-loop standing wave was produced on the wire between the bridges.

(a) Explain how an antinode is produced at the mid-point of the wire between the bridges.

(3)

.....

.....

.....

.....

.....

.....



- (b) The student repeated this for a series of tuning forks with different frequencies  $f$ . For each fork he measured the distance  $L$  between the bridges.

The steel wire, of mass per unit length  $\mu$ , was placed under tension  $T$  by hanging a mass of 2.10 kg from the end of the wire.

- (i) State one safety precaution that should be taken when carrying out the investigation.

(1)

- (ii) The student plotted a graph of  $L^2$  against  $1/f^2$ .

Show that the gradient of this graph is equal to  $\frac{T}{4\mu}$

(3)



(iii) The student's graph is shown below.

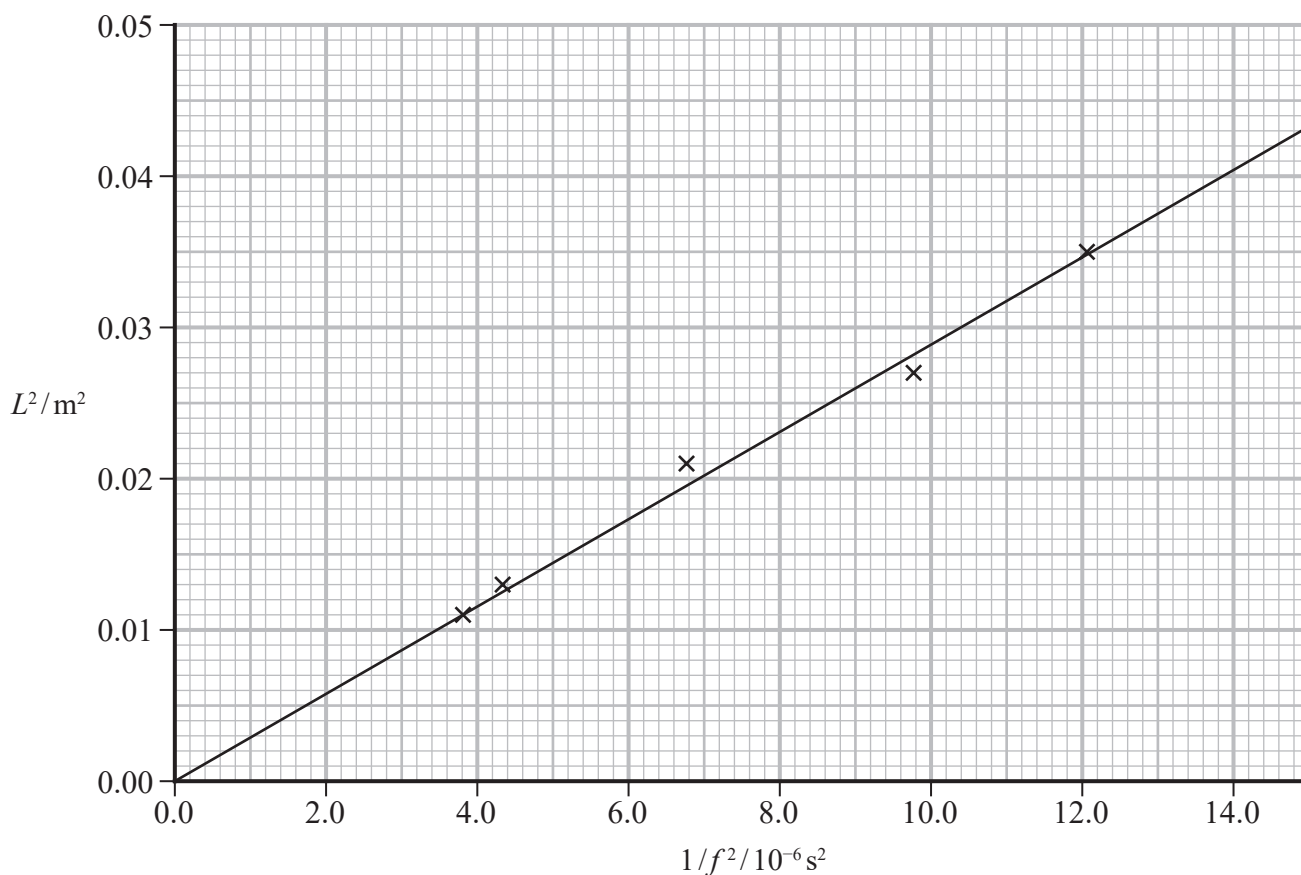

The value of  $\mu$  for different standard wire gauge (SWG) steel wire is shown in the table.

SWG	$\mu / \text{g m}^{-1}$
22	3.15
24	1.95
26	1.31

Deduce which wire the student used in the investigation.

(4)

.....

.....

.....

.....

.....

.....



(c) The student then found a value of  $\mu$  for a brass wire, using a different method.

(i) He measured the diameter  $d$  of the wire using a micrometer.

Explain one technique the student should use when measuring  $d$ .

(2)

.....

.....

.....

.....



(ii) The student obtained the following data.

$d/\text{mm}$			
0.55	0.59	0.57	0.58

The stated value of  $\mu$  for the brass wire used by the student was  $2.14 \times 10^{-3} \text{kg m}^{-1}$ .

Deduce whether the student's data supports this value for  $\mu$ .

density of brass =  $8700 \text{kg m}^{-3} \pm 200 \text{kg m}^{-3}$

(6)

.....

.....

.....

.....

.....

.....

.....

.....

.....

.....

.....

.....

.....

.....

.....

.....

.....

.....

.....

.....

.....

.....

**(Total for Question 13 = 19 marks)**

**TOTAL FOR PAPER = 120 MARKS**

DO NOT WRITE IN THIS AREA

DO NOT WRITE IN THIS AREA

DO NOT WRITE IN THIS AREA



P 6 9 4 4 4 A 0 3 1 3 6

### List of data, formulae and relationships

Acceleration of free fall	$g = 9.81 \text{ m s}^{-2}$	(close to Earth's surface)
Boltzmann constant	$k = 1.38 \times 10^{-23} \text{ J K}^{-1}$	
Coulomb law constant	$k = \frac{1}{4\pi\epsilon_0} = 8.99 \times 10^9 \text{ N m}^2 \text{ C}^{-2}$	
Electron charge	$e = -1.60 \times 10^{-19} \text{ C}$	
Electron mass	$m_e = 9.11 \times 10^{-31} \text{ kg}$	
Electronvolt	$1 \text{ eV} = 1.60 \times 10^{-19} \text{ J}$	
Gravitational constant	$G = 6.67 \times 10^{-11} \text{ N m}^2 \text{ kg}^{-2}$	
Gravitational field strength	$g = 9.81 \text{ N kg}^{-1}$	(close to Earth's surface)
Permittivity of free space	$\epsilon_0 = 8.85 \times 10^{-12} \text{ F m}^{-1}$	
Planck constant	$h = 6.63 \times 10^{-34} \text{ J s}$	
Proton mass	$m_p = 1.67 \times 10^{-27} \text{ kg}$	
Speed of light in a vacuum	$c = 3.00 \times 10^8 \text{ m s}^{-1}$	
Stefan-Boltzmann constant	$\sigma = 5.67 \times 10^{-8} \text{ W m}^{-2} \text{ K}^{-4}$	
Unified atomic mass unit	$u = 1.66 \times 10^{-27} \text{ kg}$	

#### Mechanics

Kinematic equations of motion

$$s = \frac{(u + v)t}{2}$$

$$v = u + at$$

$$s = ut + \frac{1}{2}at^2$$

$$v^2 = u^2 + 2as$$

Forces

$$\Sigma F = ma$$

$$g = \frac{F}{m}$$

$$W = mg$$

$$\text{moment of force} = Fx$$

Momentum

$$p = mv$$

Work, energy and power

$$\Delta W = F\Delta s$$

$$E_k = \frac{1}{2}mv^2$$

$$\Delta E_{\text{grav}} = mg\Delta h$$

$$P = \frac{E}{t}$$

$$P = \frac{W}{t}$$

$$\text{efficiency} = \frac{\text{useful energy output}}{\text{total energy input}}$$

$$\text{efficiency} = \frac{\text{useful power output}}{\text{total power input}}$$





## Electric circuits

Potential difference

$$V = \frac{W}{Q}$$

Resistance

$$R = \frac{V}{I}$$

Electrical power and energy

$$P = VI$$

$$P = I^2R$$

$$P = \frac{V^2}{R}$$

$$W = VIt$$

Resistivity

$$R = \frac{\rho l}{A}$$

Current

$$I = \frac{\Delta Q}{\Delta t}$$

$$I = nqvA$$

## Materials

Density

$$\rho = \frac{m}{V}$$

Stokes' law

$$F = 6\pi\eta rv$$

Hooke's law

$$\Delta F = k\Delta x$$

Young modulus

$$\text{Stress } \sigma = \frac{F}{A}$$

$$\text{Strain } \varepsilon = \frac{\Delta x}{x}$$

$$E = \frac{\sigma}{\varepsilon}$$

Elastic strain energy

$$\Delta E_{\text{el}} = \frac{1}{2}F\Delta x$$

## Waves and particle nature of light

Wave speed

$$v = f\lambda$$

Speed of a transverse wave on a string

$$v = \sqrt{\frac{T}{\mu}}$$

Intensity of radiation

$$I = \frac{P}{A}$$

Power of a lens

$$P = \frac{1}{f}$$

$$P = P_1 + P_2 + P_3 + \dots$$

Thin lens equation

$$\frac{1}{u} + \frac{1}{v} = \frac{1}{f}$$

Magnification for a lens

$$m = \frac{\text{image height}}{\text{object height}} = \frac{v}{u}$$

Diffraction grating

$$n\lambda = d \sin \theta$$

Refractive index

$$n_1 \sin \theta_1 = n_2 \sin \theta_2$$

$$n = \frac{c}{v}$$

Critical angle

$$\sin C = \frac{1}{n}$$

Photon model

$$E = hf$$

Einstein's photoelectric equation

$$hf = \phi + \frac{1}{2}mv_{\text{max}}^2$$

de Broglie wavelength

$$\lambda = \frac{h}{p}$$



## Further mechanics

Impulse

$$F\Delta t = \Delta p$$

Kinetic energy of a non-relativistic particle

$$E_k = \frac{p^2}{2m}$$

Motion in a circle

$$v = \omega r$$

$$T = \frac{2\pi}{\omega}$$

$$F = ma = \frac{mv^2}{r}$$

$$a = \frac{v^2}{r}$$

$$a = r\omega^2$$

$$F = mr\omega^2$$

## Fields

Coulomb's law

$$F = \frac{Q_1 Q_2}{4\pi\epsilon_0 r^2}$$

Electric field strength

$$E = \frac{F}{Q}$$

$$E = \frac{Q}{4\pi\epsilon_0 r^2}$$

$$E = \frac{V}{d}$$

Electric potential

$$V = \frac{Q}{4\pi\epsilon_0 r}$$

Capacitance

$$C = \frac{Q}{V}$$

Energy stored in a capacitor

$$W = \frac{1}{2}QV$$

$$W = \frac{1}{2}CV^2$$

$$W = \frac{1}{2}\frac{Q^2}{C}$$

Capacitor discharge

$$Q = Q_0 e^{-t/RC}$$

$$I = I_0 e^{-t/RC}$$

$$V = V_0 e^{-t/RC}$$

$$\ln Q = \ln Q_0 - \frac{t}{RC}$$

$$\ln I = \ln I_0 - \frac{t}{RC}$$

$$\ln V = \ln V_0 - \frac{t}{RC}$$

In a magnetic field

$$F = BIl \sin \theta$$

$$F = Bqv \sin \theta$$

Faraday's and Lenz's laws

$$\mathcal{E} = \frac{-d(N\phi)}{dt}$$

Root-mean-square values

$$V_{\text{rms}} = \frac{V_0}{\sqrt{2}}$$

$$I_{\text{rms}} = \frac{I_0}{\sqrt{2}}$$

DO NOT WRITE IN THIS AREA

DO NOT WRITE IN THIS AREA

DO NOT WRITE IN THIS AREA



## Nuclear and particle physics

In a magnetic field

$$r = \frac{p}{BQ}$$

## Thermodynamics

Heating

$$\Delta E = mc\Delta\theta$$

$$\Delta E = L\Delta m$$

Molecular kinetic theory

$$\frac{1}{2}m\langle c^2 \rangle = \frac{3}{2}kT$$

$$pV = \frac{1}{3}Nm\langle c^2 \rangle$$

Ideal gas equation

$$pV = NkT$$

Stefan-Boltzmann law

$$L = \sigma AT^4$$

$$L = 4\pi r^2\sigma T^4$$

Wien's law

$$\lambda_{\max} T = 2.898 \times 10^{-3} \text{ m K}$$

## Space

Intensity

$$I = \frac{L}{4\pi d^2}$$

Redshift of electromagnetic radiation

$$z = \frac{\Delta\lambda}{\lambda} \approx \frac{\Delta f}{f} \approx \frac{v}{c}$$

Cosmological expansion

$$v = H_0 d$$

## Nuclear radiation

Mass-energy

$$\Delta E = c^2\Delta m$$

Radioactive decay

$$A = \lambda N$$

$$\frac{dN}{dt} = -\lambda N$$

$$\lambda = \frac{\ln 2}{t_{1/2}}$$

$$N = N_0 e^{-\lambda t}$$

$$A = A_0 e^{-\lambda t}$$

## Gravitational fields

Gravitational force

$$F = \frac{Gm_1 m_2}{r^2}$$

Gravitational field strength

$$g = \frac{Gm}{r^2}$$

Gravitational potential

$$V_{\text{grav}} = \frac{-Gm}{r}$$

## Oscillations

Simple harmonic motion

$$F = -kx$$

$$a = -\omega^2 x$$

$$x = A \cos \omega t$$

$$v = -A\omega \sin \omega t$$

$$a = -A\omega^2 \cos \omega t$$

$$T = \frac{1}{f} = \frac{2\pi}{\omega}$$

$$\omega = 2\pi f$$

Simple harmonic oscillator

$$T = 2\pi \sqrt{\frac{m}{k}}$$

$$T = 2\pi \sqrt{\frac{l}{g}}$$



DO NOT WRITE IN THIS AREA

DO NOT WRITE IN THIS AREA

DO NOT WRITE IN THIS AREA

**BLANK PAGE**

